



Viæ • { ã•ã } / Óæ ã, ãcÓ		€ GET P: Á
Ô@ææc!ã æVQ] ^ãæ &^Á		ííóÁ
Y ã@ææ äã * Áç æ^Á	Ù^æç^ç^Á	í€EXÁ
	GFE€€€	Fí€X
X æ^Á [] Á	Ô^ ç!Á } ææc	£Fí Á XÁFÓÁ
	Qç! { ^ãææ^Á } ææc	£Fí Á XÁFÓÁ
	U^ ç!Á } ææc	£Hí Á XÁFÓÁ

Ž [{ [] Áã } ææc

Ú | , ^!Á | } ææcææ ã^Á • çç^ãÁ Áæ • { ã@Á | { [] Áã } ææc

Ô } ææcã^Á		GGÓÁ } ææc	G€^Á } ææc
Y ã@ææ äã * Áç æ^Á	Ù^æç^ç^Á	FG€EXÁ	Fí€EXÁ
	HEí€	í€EX	ì€EX
Üæ^ãÁ ^} c		í c	ì È c

Ž | } ææcãã } ææc

U | } ææcã^!Á | } ææcææ ã^Á • çç^ãÁ Áæ • { ã@Á | } ææcãã } ææc

Ô } ææcã^Á		Fí^Á ææc	FG^Á ææc
Qç! ç! } Á ••Á		mÈí áÓÁ	mÈí áÓÁ
Ü^ ^ ç! } Á		mÈí áÓÁ	mÈí áÓÁ

Žã ç!^~^} & Áã } ææc

Ô | } ææc^Á | } ææcææ ã^Á • çç^ãÁ Áæ • { ã@Á ç!^~^} & Áã } ææc

Ô } ææc^Á } ææc		FG^Á ææc & } ææc	í^Á ææc^Á } ææc	í^Á ææc^Á } ææc	FÁ } ææc^Á } ææc
Ô@ææc!ã æVQ] ^ãæ &^Á		í€Á	ííóÁ	ííóÁ	í€Á
Óæ ã, ãc@		€ HÖP:	€ í€ET P:	€ í€ET P: Á	€ íÖP: Á
Y ã@ææ äã * Áç æ^Á	Ù^æç^ç^Á	J€EXÁ	í€EXÁ	ì€EXÁ	ííEXÁ
	GFE€€€ Á	GíEXÁ	GíEXÁ	GíEXÁ	GíEXÁ
Ô } ææc !ãææ &^Á	Ô^ ç!Á } ææc	£HE(ô	£FEÁ ô Á	£FEÁ ô Á	£FÁ ô Á
	U^ ç!Á } ææc	£Ií(ô	£FEÁ ô Á	£FEÁ ô Á	£EÁ ô Á
XÜY Ü		FÈH F	FÈH FÁ	FÈH FÁ	FÈ FÁ
Qç! ç! } Á ••Á		mÈí áÓÁ	mÈí áÓÁ	mÈí áÓÁ	mÈí áÓÁ

Ordering Information

Basic series	X0	W	2	TS	Y	013
Plating	W—Cadmium plating F—Nickel plating					
Shell size	2—2 cavities standard shell 3—4 cavities standard shell 4—6 cavities standard shell					
Connector and contact type	TS—Plug (with socket) ZP—Receptacle (with pin)					
Termination type	Y—Crimp B—PCB (only applicable to receptacle)					
Combination code	Ù^Á } äã ææ } / Á ã^Á æ^Á dFED					



Mounting style

Óä\ . Úä äääÁ

Òä]|^: X0F2TSY291 X0-2 series crimped plug nickel plating with the combination code 291
X0F2ZPY291 X0-2 series crimped receptacle nickel plating with the combination code 291

[Notes]

1. Pins should be installed in the 22D insert of plug and sockets should be installed in the other inserts. Sockets should be installed in the 22D insert of receptacle and pins should be installed in the other inserts. Other contact sizes, not 22D contact size, would be considered during ordering;
2. 2D, 20[#], 16[#] and 12[#] contacts can be supplied with the finished products and applicable high frequency, coaxial, differential and optical fiber contacts should be ordered separately
3. There is no locking mechanism between plug and receptacle and the locking can be met by the locking mechanism of the applicable equipments. The mounting style and the mating dimension are as shown in Figure 1:
4. X0 series metallic rack and panel connector should be installed on the panel with bolts. The recommended mounting style for receptacle is rear mounting from the interior of the cabinet. The recommended mounting style for plug is rear mounting from the interior of the cabinet. (Note: The column protrusion on the square flange, not the mounting hole is the locating reference as shown in Figure 1), which can assure the design reference, part process reference, connector mounting reference and cabinet mating reference and ensure the mating of connector. If the lateral mounting style is selected, the plug should be at least 0.5mm over the receptacle due to the gap between the cabinet and rack.
5. During the mating, if there is any problem on the mating, the rear of the cabinet should be pressed; the front end can be raised and then mated with plug on the rack. If there is no problem, the operation does not need.

Simplified figure of structure

[Simplified figure of plug combination]

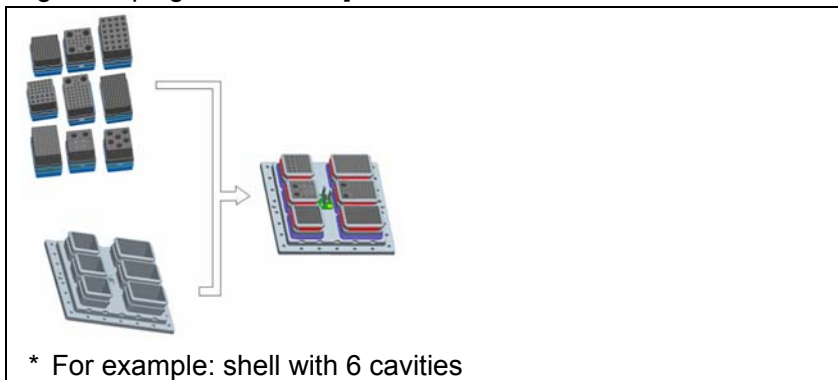

[Simplified figure of receptacle combination]

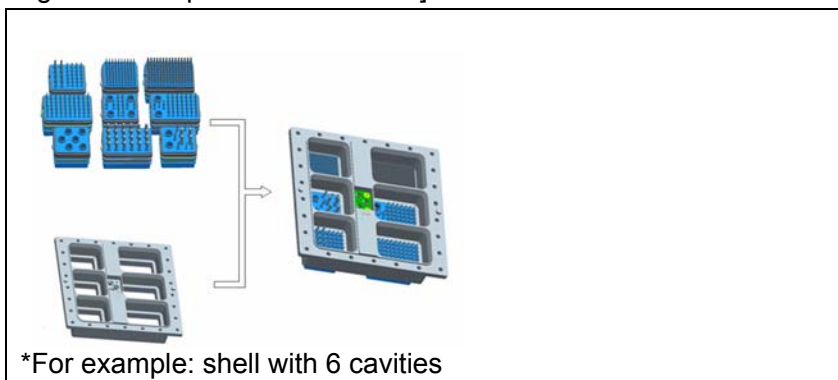

[Sketch map for the mating of plug and receptacle]

There is no locking mechanism between X0 series plug and receptacle and the locking can be met by the locking mechanism of the applicable equipments. The mounting style and the mating dimension are as shown in Figure 1:

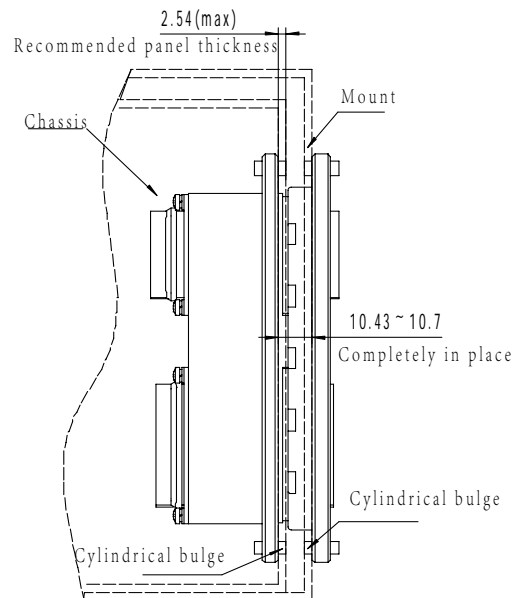
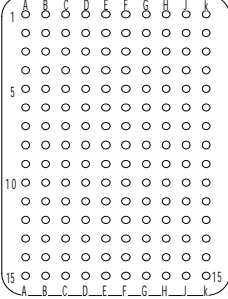
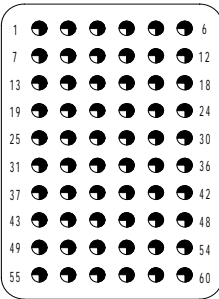
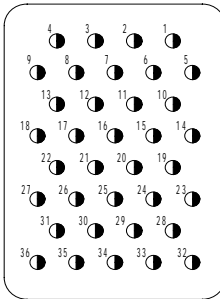
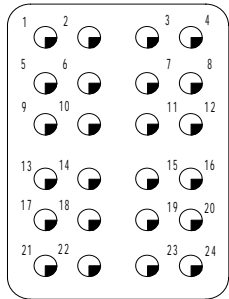
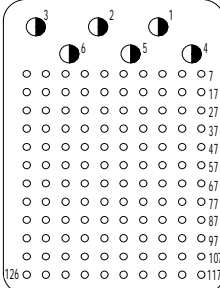
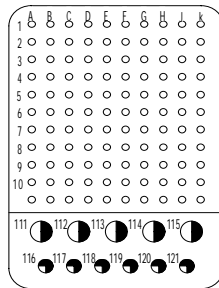
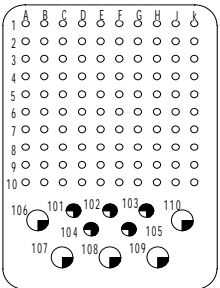
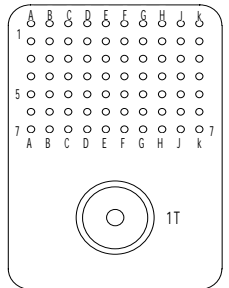
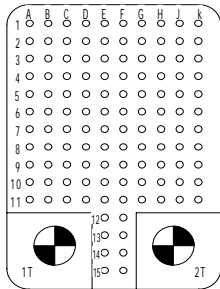
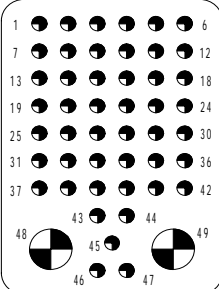
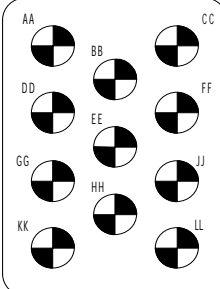
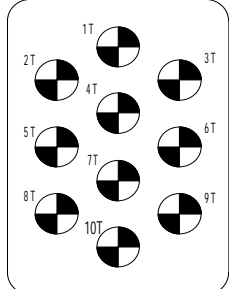
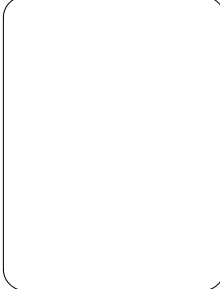
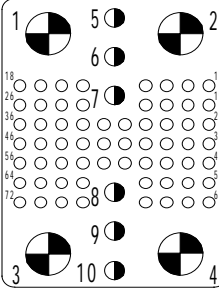
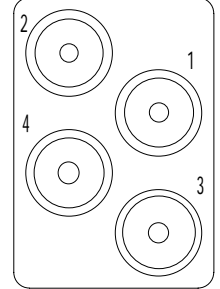
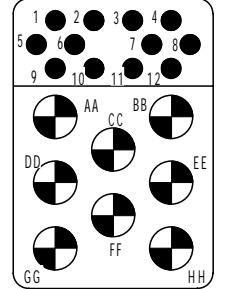

Figure 1: The mating dimension of X0 series plug and receptacle



VI: Insert arrangement (Front face of socket inserts)

[Standard shell A, B or E cavity insert arrangement]

<p style="text-align: center;">I - 150</p>  <p style="text-align: center;">150-22D</p>	<p style="text-align: center;">I - 60</p>  <p style="text-align: center;">60-20[#]</p>	<p style="text-align: center;">I - 36A</p>  <p style="text-align: center;">36-16[#]</p>	<p style="text-align: center;">I - 24</p>  <p style="text-align: center;">24-12[#]</p>
<p style="text-align: center;">I - 126</p>  <p style="text-align: center;">120-22D, 6-16[#]</p>	<p style="text-align: center;">I - 121</p>  <p style="text-align: center;">110-22D, 6-20[#], 5-16[#]</p>	<p style="text-align: center;">I - 110</p>  <p style="text-align: center;">100-22D, 5-20[#], 5-12[#]</p>	<p style="text-align: center;">I - 70C1</p>  <p style="text-align: center;">70-22D, 1-1[#]</p>
<p style="text-align: center;">I - 120T2</p>  <p style="text-align: center;">118-22D, 2-8[#]</p>	<p style="text-align: center;">I - 47T2</p>  <p style="text-align: center;">47-20[#], 2-8[#]</p>	<p style="text-align: center;">I - 11T11</p>  <p style="text-align: center;">11-8[#]</p>	<p style="text-align: center;">I - 10T10</p>  <p style="text-align: center;">10-8[#]</p>
<p style="text-align: center;">I - 0</p>  <p style="text-align: center;">No contact</p>	<p style="text-align: center;">I-72T4</p>  <p style="text-align: center;">62-22D, 6-16[#], 4-8[#]</p>	<p style="text-align: center;">I-C4</p>  <p style="text-align: center;">4-1[#]</p>	<p style="text-align: center;">I-20F12T8</p>  <p style="text-align: center;">12-16[#]optical fiber, 8-8[#]</p>

Note: The letter K in I - 150, I - 121, I - 110 I - 70C1, I - 120T2 insert arrangement can not be printed due to limited space, but K is defaulted to be the last row of the cavity

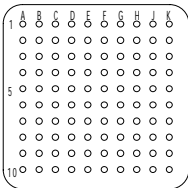
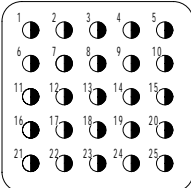
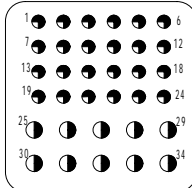
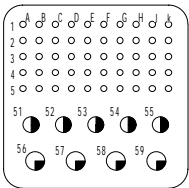
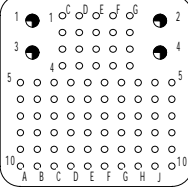
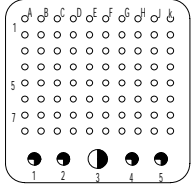
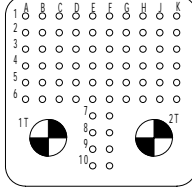
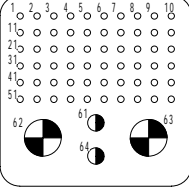
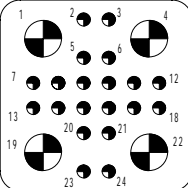
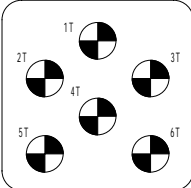
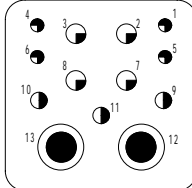
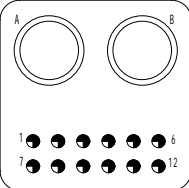
[Standard shell B, D or F cavity insert arrangement]

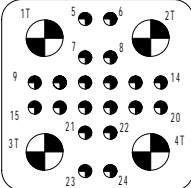
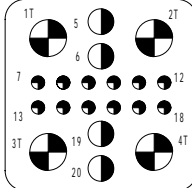
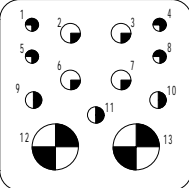
<p style="text-align: center;">II - 100</p>  <p style="text-align: center;">100-22D</p>	<p style="text-align: center;">II - 25</p>  <p style="text-align: center;">25-16#</p>	<p style="text-align: center;">II - 34</p>  <p style="text-align: center;">24-20#, 10-16#</p>	<p style="text-align: center;">II - 59</p>  <p style="text-align: center;">50-22D, 5-16#, 4-12#</p>
<p style="text-align: center;">II - 84</p>	<p style="text-align: center;">II - 85</p>	<p style="text-align: center;">II - 70T2</p>	<p style="text-align: center;">II - 64T2</p>
 <p style="text-align: center;">80-22D, 4-20#</p>	 <p style="text-align: center;">80-22D, 4-20#, 1-16#</p>	 <p style="text-align: center;">68-22D, 2-8#</p>	 <p style="text-align: center;">60-22D, 2-16#, 2-8#</p>
<p style="text-align: center;">II - 20T4</p>	<p style="text-align: center;">II - 6T6</p>	<p style="text-align: center;">II - 13W2</p>	<p style="text-align: center;">II - CAN</p>
 <p style="text-align: center;">20-20#, 4-8#</p>	 <p style="text-align: center;">6-8#</p>	 <p style="text-align: center;">4-20#, 3-16#, 4-12#, 2-5#</p>	 <p style="text-align: center;">12-20#, 2-CAN contact</p>
<p style="text-align: center;">II - 0</p>	<p style="text-align: center;">II - 20T4A</p>	<p style="text-align: center;">II - 20T4G4</p>	<p style="text-align: center;">II - 11T2</p>
 <p style="text-align: center;">No contact</p>	 <p style="text-align: center;">20-20#, 4-8#</p>	 <p style="text-align: center;">20-20#, 4-16#, 4-8#</p>	 <p style="text-align: center;">4-20#, 3-16#, 4-12#, 2-8#</p>

Contact specification ○22D ●20# ◐16# ◑12# ◒8# ◓5# ⊙1#

Product Combination Code Table

Product combination code	Shell size	Insert arrangements					
		A	B	C	D	E	F
001	2 [#]	I -47T2	II -100	—	—	—	—
002	2 [#]	I -47T2	II -20T4	—	—	—	—
003	2 [#]	I -47T2	II -34	—	—	—	—
004	3 [#]	I -150	II -34	I -150	II -20T4	—	—
005	3 [#]	I -150	II -100	I -47T2	II -100	—	—
006	3 [#]	I -60	II -100	I -60	II -100	—	—
007	3 [#]	I -150	II -100	I -150	II -100	—	—
008	3 [#]	I -60	II -34	I -60	II -34	—	—
009	4 [#]	I -150	II -34	I -150	II -20T4	I -150	II -20T4
010	4 [#]	I -24	II -34	I -150	II -100	I -150	II -20T4
011	4 [#]	I -150	II -34	I -150	II -20T4	I -150	II -6T6
012	4 [#]	I -24	II -34	I -150	II -0	I -150	II -20T4

201	2 [#]	I -150	II -34	—	—	—	—
202	2 [#]	I -150	II -20T4	I -0	II -100	—	—
203	2 [#]	I -126	II -100	—	—	—	—
204	2 [#]	I -150	II -13W2	—	—	—	—
205	3 [#]	I -150	II -6T6	I -150	II -6T6	—	—
206	3 [#]	I -150	II -34	I -150	II -20T4	—	—
207	2 [#]	I -150	II -20T4	—	—	—	—
208	3 [#]	I -150	II -20T4	I -150	II -0	—	—
209	2 [#]	I -47T2	II -13W2	—	—	—	—
210	3 [#]	I -150	II -13W2	I -24	II -100	—	—
211	2 [#]	I -150	II -11T2	—	—	—	—
212	2 [#]	I -60	II -11T2	—	—	—	—
213	3 [#]	I -24	II -34	I -24	II -20T4	—	—
214	3 [#]	I -24	II -34	I -0	II -20T4	—	—
216	2 [#]	I -150	II -100	—	—	—	—
217	2 [#]	I -24	II -13W2	—	—	—	—
218	3 [#]	I -24	II -13W2	I -24	II -6T6	—	—
219	4 [#]	I -24	II -13W2	I -47T2	II -34	I -24	II -20T4
220	4 [#]	I -150	II -100	I -150	II -100	I -150	II -100
221	4 [#]	I -24	II -34	I -150	II -20T4	I -150	II -6T6
222	3 [#]	I -150	II -11T2	I -24	II -100	—	—

Product combination code	Shell size	Insert arrangements					
		A	B	C	D	E	F
223	3 [#]	I -150	II -13W2	I -150	II -13W2	—	—
224	2 [#]	I -150	II -64T2	—	—	—	—
225	2 [#]	I -60	II -20T4	—	—	—	—
226	3 [#]	I -150	II -34	I -150	II -100	—	—
227	3 [#]	I -150	II -20T4	I -24	II -0	—	—
228	3 [#]	I -150	II -100	I -150	II -20T4	—	—
229	3 [#]	I -150	II -20T4	I -24	II -13W2	—	—
230	2 [#]	I -47T2	II -0	—	—	—	—
231	2 [#]	I -24	II -0	—	—	—	—
232	2 [#]	I -24	II -34	—	—	—	—
233	3 [#]	I -150	II -34	I -150	II -34	—	—
234	3 [#]	I -24	II -13W2	I -150	II -100	—	—
235	3 [#]	I -150	II -0	I -150	II -20T4	—	—
236	4 [#]	I -24	II -34	I -24	II -0	I -150	II -20T4
237	2 [#]	I -24	II -100	—	—	—	—
238	3 [#]	I -0	II -13W2	I -0	II -20T4	—	—
239	3 [#]	I -24	II -34	I -24	II -34	—	—
240	3 [#]	I -47T2	II -34	I -24	II -34	—	—
241	4 [#]	I -24	II -34	I -24	II -34	I -24	II -34
242	3 [#]	I -0	II -13W2	I -0	II -34	—	—
243	3 [#]	I -60	II -34	I -24	II -34	—	—
244	4 [#]	I -60	II -34	I -60	II -34	I -24	II -34
245	3 [#]	I -150	II -13W2	I -24	II -13W2	—	—
246	4 [#]	I -24	II -34	I -60	II -100	I -150	II -20T4
247	4 [#]	I -24	II -34	I -24	II -100	I -150	II -20T4
248	4 [#]	I -60	II -6T6	I -60	II -6T6	I -24	II -6T6
249	4 [#]	I -60	II -6T6	I -0	II -6T6	I -150	II -6T6
250	3 [#]	I -24	II -0	I -150	II -20T4	—	—
251	3 [#]	I -126	II -34	I -126	II -20T4	—	—
252	3 [#]	I -150	II -34	I -0	II -13W2	—	—
253	3 [#]	I -24	II -100	I -150	II -20T4	—	—
254	3 [#]	I -150	II -64T2	I -150	II -64T2	—	—
255	3 [#]	I -150	II -13W2	I -0	II -34	—	—
256	2 [#]	I -60	II -13W2	—	—	—	—
258	3 [#]	I -150	II -13W2	I -150	II -34	—	—
259	4 [#]	I -150	II -20T4	I -24	II -6T6	I -150	II -11T2
260	3 [#]	I -150	II -6T6	I -150	II -34	—	—
261	3 [#]	I -150	II -13W2	I -126	II -34	—	—
262	3 [#]	I -150	II -100	I -150	II -64T2	—	—



Product code	Shell size	Insert arrangements					
		A	B	C	D	E	F
263	2 [#]	I -60	II -34	—	—	—	—
264	3 [#]	I -150	II -6T6	I -150	II -100	—	—
266	2 [#]	I -47T2	II -11T2	—	—	—	—
267	4 [#]	I -150	II -34	I -150	II -100	I -150	II -34
268	Without insert arrangements						
269	2 [#]	I -126	II -11T2	—	—	—	—
270	3 [#]	I -150	II -11T2	I -150	II -20T4	—	—
271	3 [#]	I -150	II -11T2	I -150	II -11T2	—	—
272	4 [#]	I -150	II -34	I -150	II -100	I -150	II -20T4
273	4 [#]	I -126	II -100	I -150	II -100	I -126	II -100
275	3 [#]	I -150	II -6T6	I -150	II -0	—	—
276	2 [#]	I -150	II -6T6	—	—	—	—
278	3 [#]	I -150	II -20T4	I -150	II -20T4	—	—
279	3 [#]	I -60	II -20T4	I -60	II -20T4	—	—
280	4 [#]	I -150	II -100	I -150	II -100	I -150	II -62T4
281	3 [#]	I -150	II -13W2	I -150	II -100	—	—
282	3 [#]	I -150	II -11T2	I -150	II -100	—	—
283	3 [#]	I -0	II -20T4	I -150	II -20T4	—	—
284	3 [#]	I -150	II -20T4	I -150	II -100	—	—
285	3 [#]	I -150	II -20T4	I -150	II -13W2	—	—
286	3 [#]	I -126	II -6T6	I -150	II -20T4	—	—
287	3 [#]	I -150	II -13W2	I -150	II -20T4	—	—
288	2 [#]	I -120T2	II -34				
289	3 [#]	I -60	II -20T4	I -60	II -6T6		
290	2 [#]	I -70C1	II -6T6				
291	2 [#]	I -60	II -6T6				
292	4 [#]	I -150	II -6T6	I -150	II -6T6	I -150	II -6T6
293	2 [#]	I -36	II -6T6				
294	3 [#]	I -150	II -25	I -11T11	II -6T6		
295	2 [#]	I -11T11	II -100				
296	2 [#]	I -126	II -6T6				
297	2 [#]	I -24	II -20T4				
298	4 [#]	I -150	II -6T6	I -126	II -6T6	I -126	II -100
299	2 [#]	I -121	II -64T2				
300	3 [#]	I -60	II -25	I -11T11	II -13W2		
301	4 [#]	I -150	II -100	I -60	II -100	I -150	II -25
302	3 [#]	I -10T10	II -25	I -24	II -20T4		
303	3 [#]	I -60	II -59				
304	3 [#]	I -150	II -6T6	I -150	II -13W2		
305	3 [#]	I -10T10	II -20T4A	I -36	II -100		

Product combination code	Shell size	Insert arrangements					
		A	B	C	D	E	F
306	3 [#]	I-120T2	II-6T6	I-11T11	II-11T2	—	—
307	2 [#]	I-24	II-25	—	—	—	—
308	3 [#]	I -150	II -70T2	I -150	II -70T2	—	—
309	3 [#]	I -36A	II -100	I -36A	II -100	—	—
310	3 [#]	I-126	II -100	I-126	II -100	—	—
311	3 [#]	I-120T2	II -100	I-126	II -100	—	—
312	2 [#]	I -10T10	II -20T4A	—	—	—	—
313	3 [#]	I-24	II-25	I-120T2	II-25	—	—
314	3 [#]	I -150	II-25	I -150	II-25	—	—
315	2 [#]	I -150	II-25	—	—	—	—
316	2 [#]	I-120T2	II-59	—	—	—	—
317	3 [#]	I -150	II-25	I -24	II-59	—	—
318	3 [#]	I -24	II -100	I -10T10	II-25	—	—
319	4 [#]	I -150	II-25	I-11T11	II-6T6	I -24	II-6T6
320	2 [#]	I -24	II -100	—	—	—	—
321	2 [#]	I-120T2	II-25	—	—	—	—

V Outline dimensions

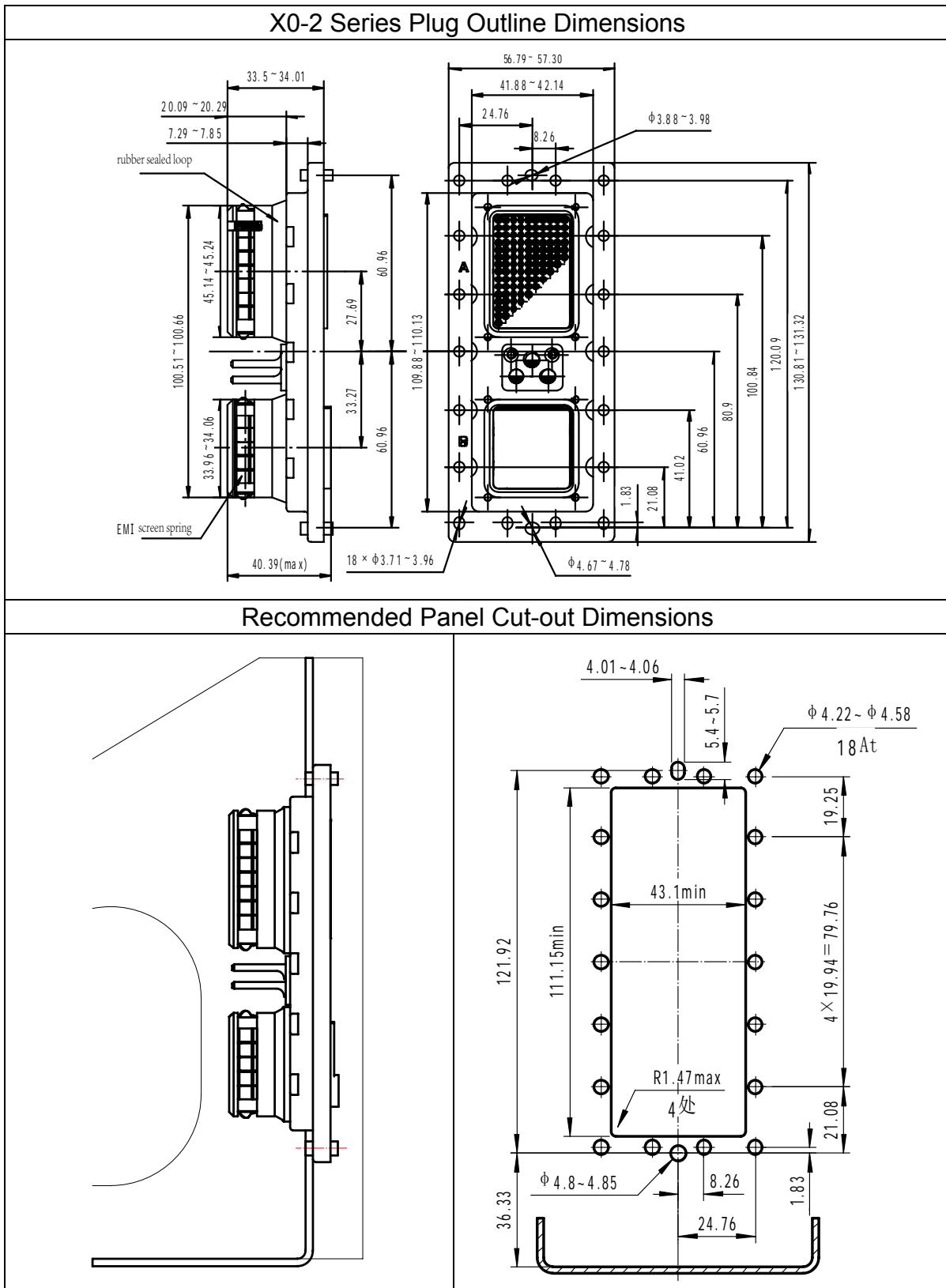



X0-2 Series Receptacle Outline Dimensions

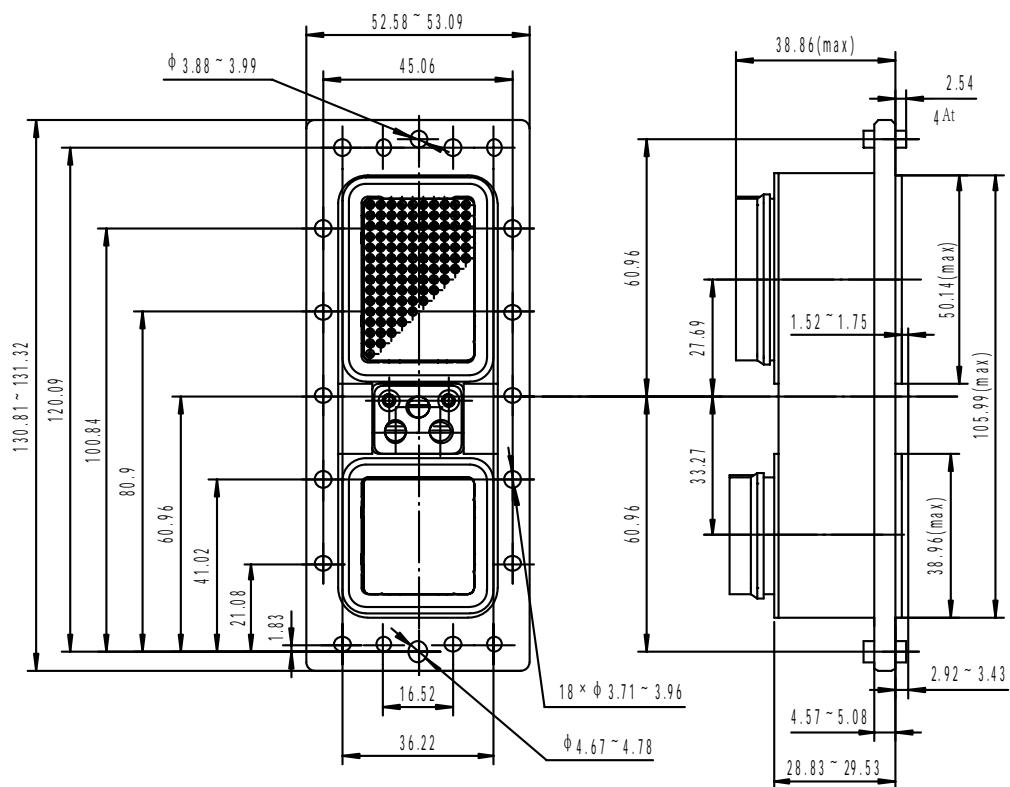

Recommended Panel Cut-out Dimensions

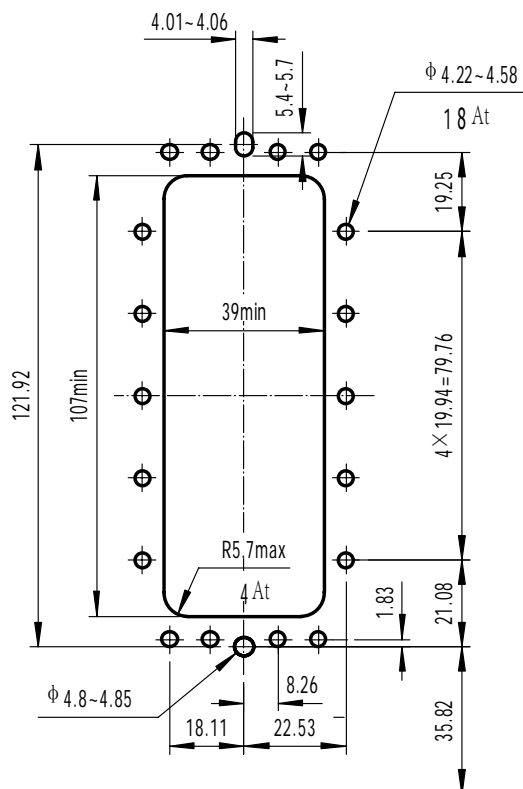
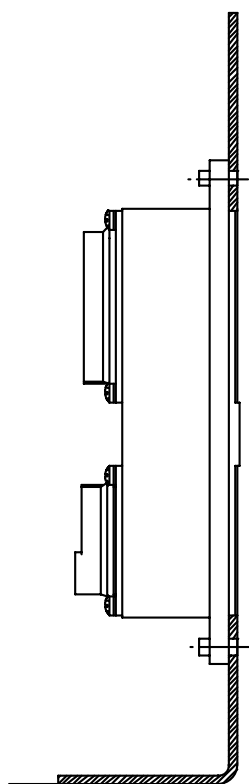

X0-3 Series Plug Outline Dimensions

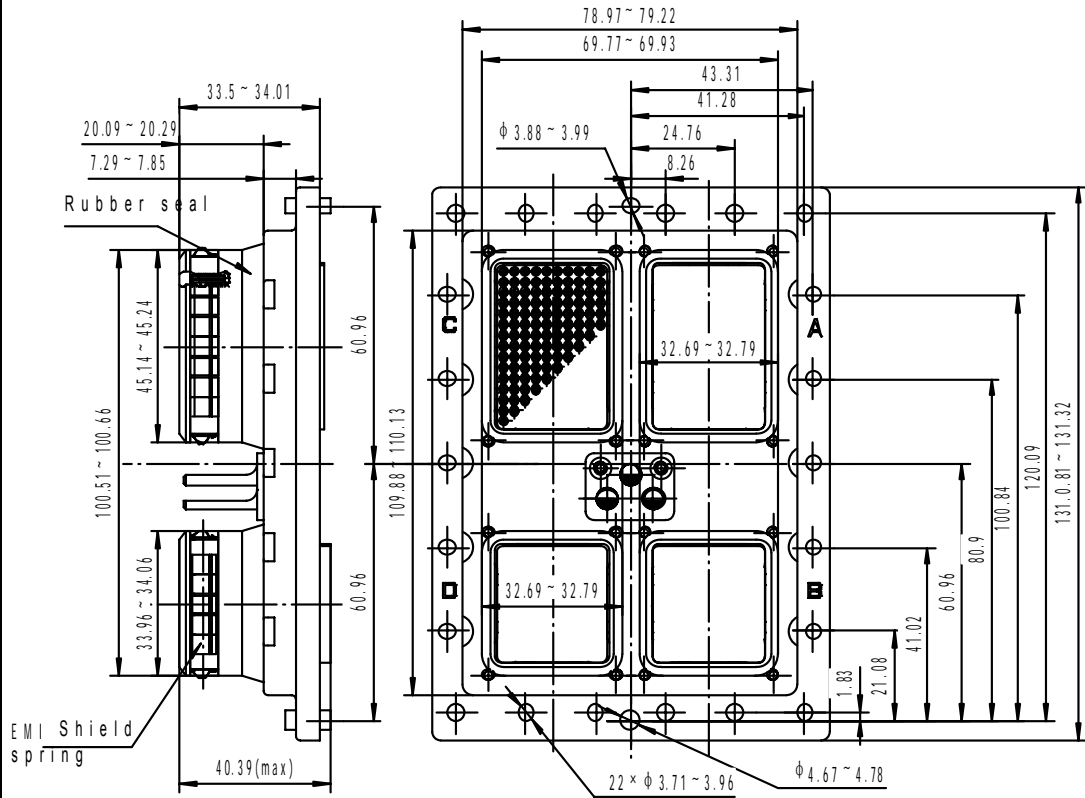

Recommended Panel Cut-out Dimensions

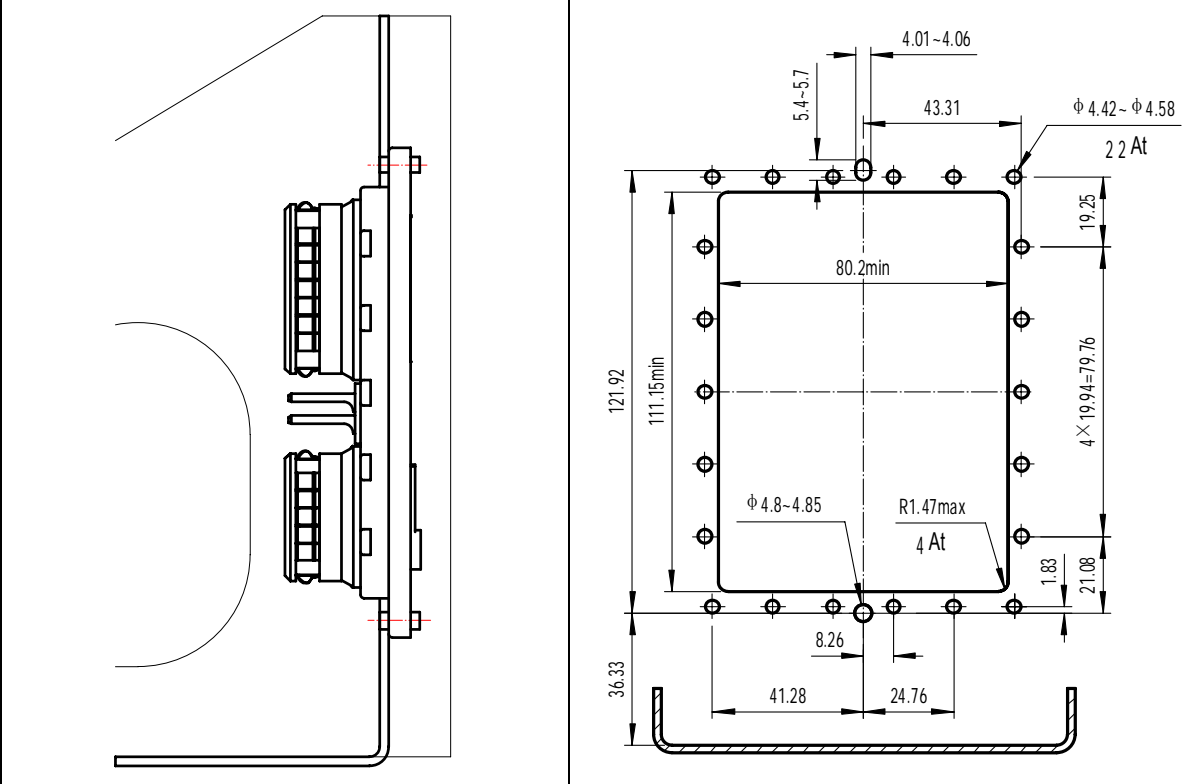

X0-3 Series Receptacle Outline Dimensions

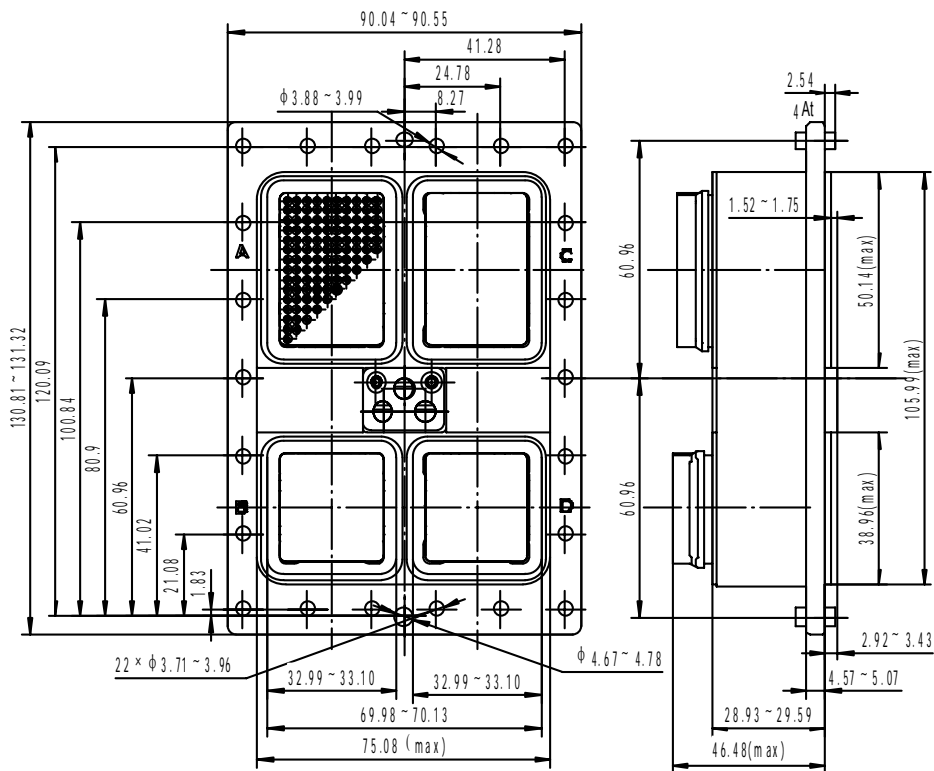

Recommended Panel Cut-out Dimensions

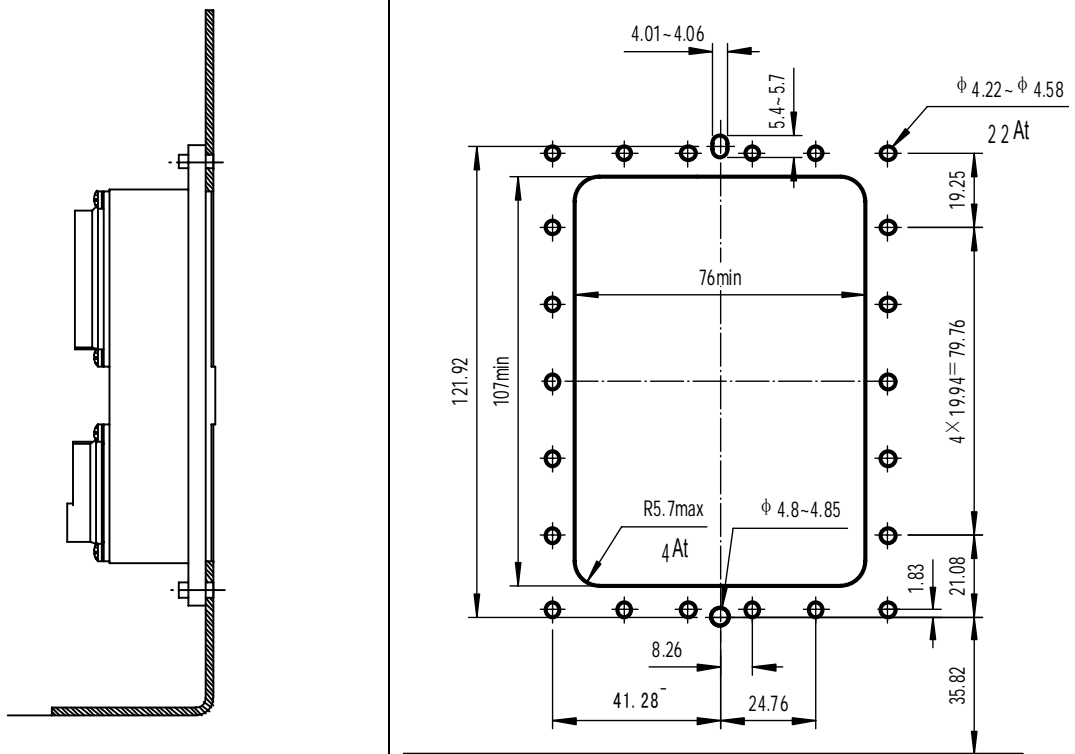



X0-4 Series Plug Outline Dimensions

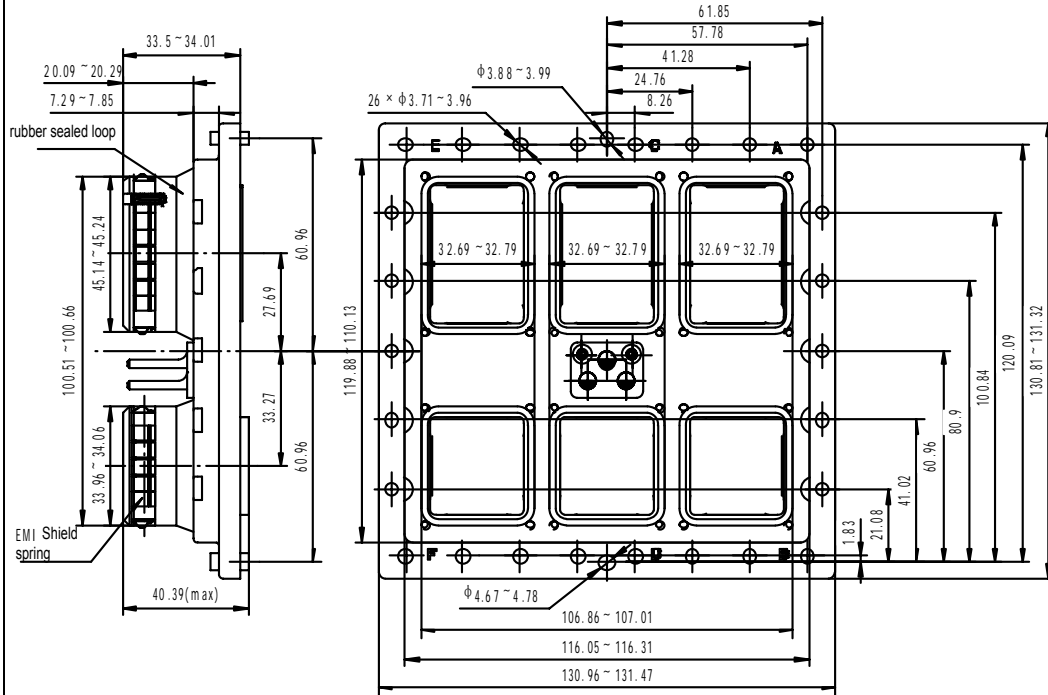

Recommended Panel Cut-out Dimensions

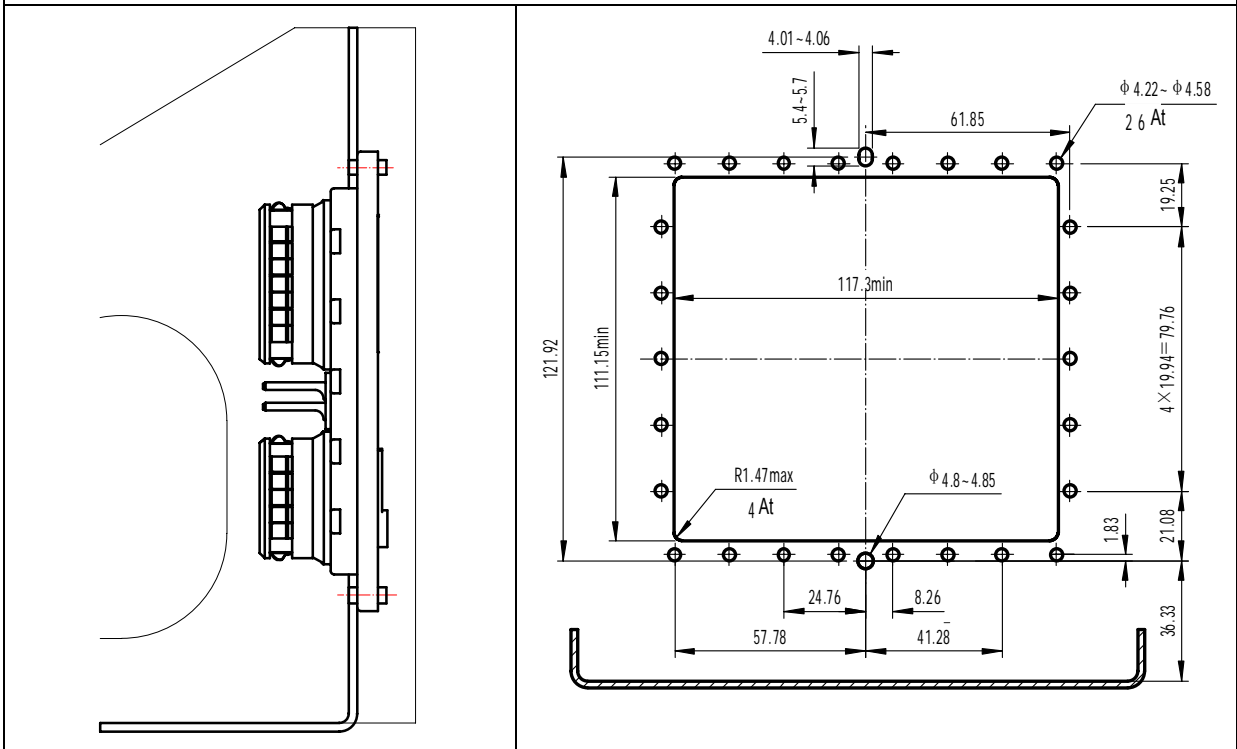

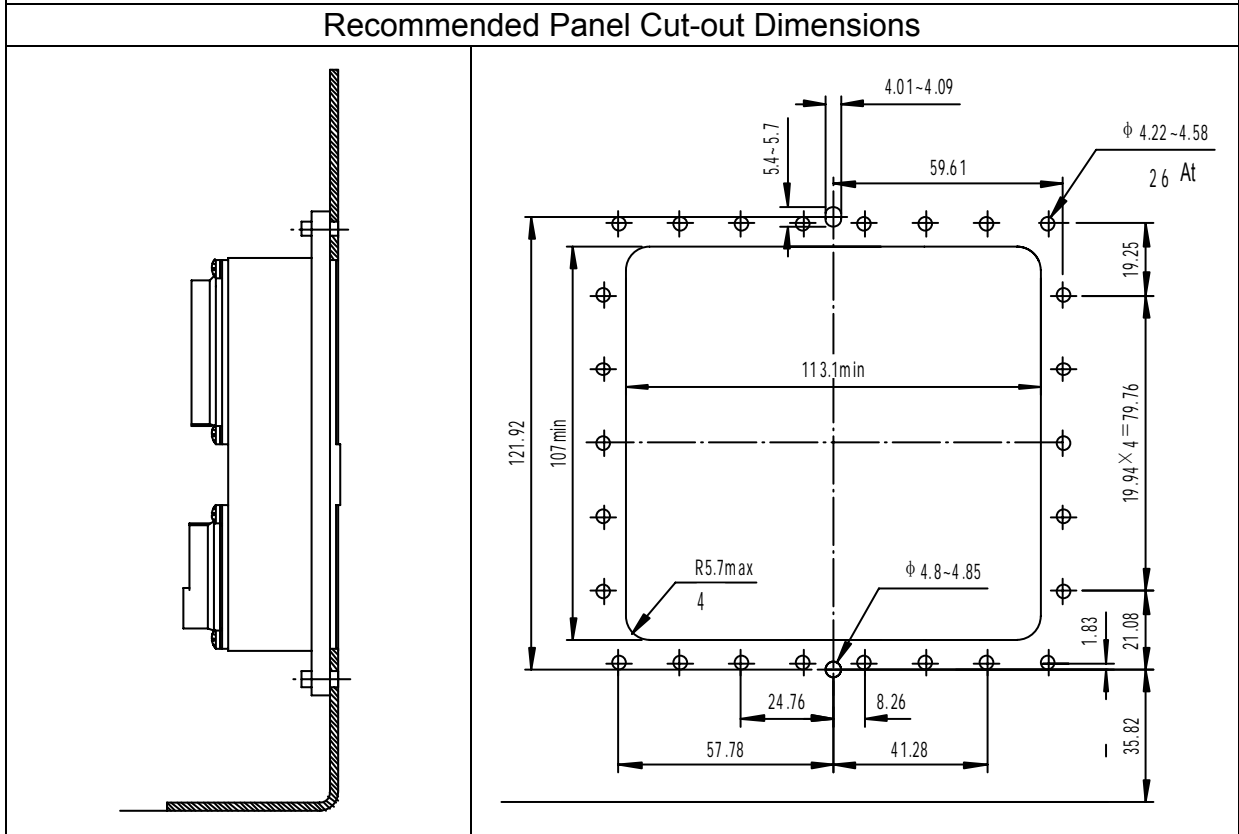
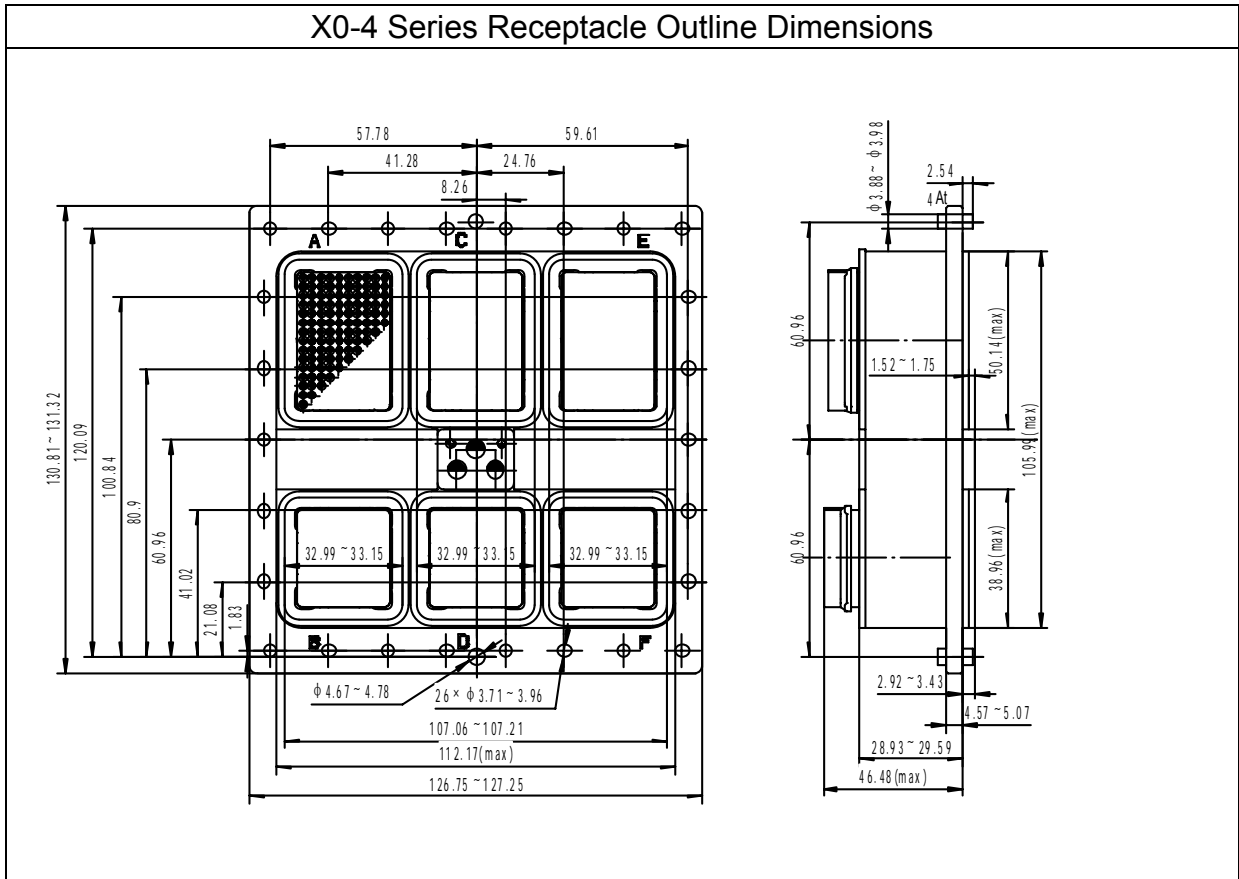

VI Mis-mating proof device

[Connector polarization]

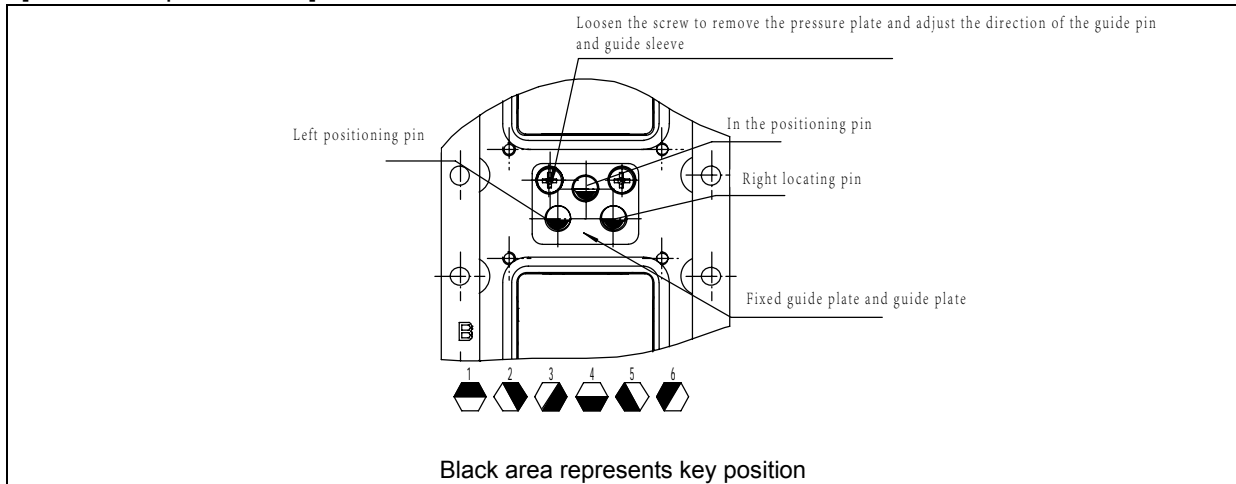

[Key]

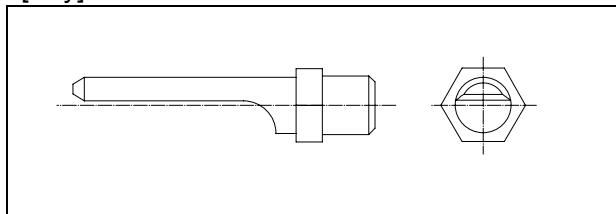

[Keyway]

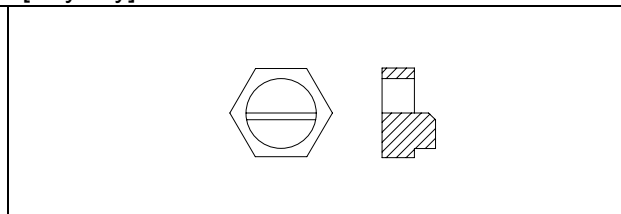

Plug			Receptacle			Plug			Receptacle		
Left Key	Center Key	Right Key	Left Key	Center Key	Right Key	Left Key	Center Key	Right Key	Left Key	Center Key	Right Key
00	—	—	00	—	—	25	1	1	25	2	4
01	1	1	01	4	4	26	2	1	26	2	3
02	2	1	02	4	4	27	3	1	27	2	2
03	3	1	03	4	4	28	4	1	28	2	1
04	4	1	04	4	4	29	5	1	29	2	6
05	5	1	05	4	4	30	6	1	30	2	5
06	6	1	06	4	4	31	1	1	31	3	4
07	1	1	07	5	4	32	2	1	32	3	3
08	2	1	08	5	4	33	3	1	33	3	2
09	3	1	09	5	4	34	4	1	34	3	1
10	4	1	10	5	4	35	5	1	35	3	6
11	5	1	11	5	4	36	6	1	36	3	5
12	6	1	12	5	4	37	1	2	37	4	4
13	1	1	13	6	4	38	2	2	38	4	3
14	2	1	14	6	4	39	3	2	39	4	2
15	3	1	15	6	4	40	4	2	40	4	1
16	4	1	16	6	4	41	5	2	41	4	6
17	5	1	17	6	4	42	6	2	42	4	5
18	6	1	18	6	4	43	1	2	43	4	4
19	1	1	19	1	4	44	2	2	44	5	3
20	2	1	20	1	4	45	3	2	45	5	2
21	3	1	21	1	4	46	4	2	46	5	1
22	4	1	22	1	4	47	5	2	47	5	6
23	5	1	23	1	4	48	6	2	48	5	5
24	6	1	24	1	4	49	1	2	49	6	4

Plug			Receptacle			Plug			Receptacle						
Left Key	Center Key	Right Key	Left Key	Center Key	Right Key	Left Key	Center Key	Right Key	Left Key	Center Key	Right Key				
50	2	2	5	50	6	3	3	75	3	3	1	75	4	2	2
51	3	2	5	51	6	3	2	76	4	3	1	76	4	2	1
52	4	2	5	52	6	3	1	77	5	3	1	77	4	2	6
53	5	2	5	53	6	3	6	78	6	3	1	78	4	2	5
54	6	2	5	54	6	3	5	79	1	3	6	79	5	2	4
55	1	2	4	55	1	3	4	80	2	3	6	80	5	2	3
56	2	2	4	56	1	3	3	81	3	3	6	81	5	2	2
57	3	2	4	57	1	3	2	82	4	3	6	82	5	2	1
58	4	2	4	58	1	3	1	83	5	3	6	83	5	2	6
59	5	2	4	59	1	3	6	84	6	3	6	84	5	2	5
60	6	2	4	60	1	3	5	85	1	3	5	85	5	2	4
61	1	2	3	61	2	3	4	86	2	3	5	86	5	2	3
62	2	2	3	62	2	3	3	87	3	3	5	87	6	2	2
63	3	2	3	63	2	3	2	88	4	3	5	88	6	2	1
64	4	2	3	64	2	3	1	89	5	3	5	89	6	2	6
65	5	2	3	65	2	3	6	90	6	3	5	90	6	2	5
66	6	2	3	66	2	3	5	91	1	3	4	91	1	2	4
67	1	2	2	67	3	3	4	92	2	3	4	92	1	2	3
68	2	2	2	68	3	3	3	93	3	3	4	93	1	2	2
69	3	2	2	69	3	3	2	94	4	3	4	94	1	2	1
70	4	2	2	70	3	3	1	95	5	3	4	95	1	2	6
71	5	2	2	71	3	3	6	96	6	3	4	96	1	2	5
72	6	2	2	72	3	3	5	97	1	3	3	97	2	2	4
73	1	3	1	73	4	2	4	98	2	3	3	98	2	2	3
74	2	3	1	74	4	2	3	99	3	3	3	99	2	2	2

VII Contact and removal tool

Contact size	Contact style	Dia mm	I.D. of wire barrel mm	Cross section mm ²	Wire gauge AWG	O.D. of wire insulation mm	Crimping tool P/N
22D	Pin	Φ0.78	Φ0.89	0.08	28	0.76~1.37	M81969/1-01
	Socket			0.125	26		
				0.2	24		
20 [#]	Pin	Φ1.00	Φ1.00	0.3	22	1.02~2.11	M81969/1-02
	Socket			0.5	20		
16 [#]	Pin	Φ1.60	Φ1.68	0.5	20	1.65~2.77	M81969/1-03
	Socket			0.8	18		
				1.0	16		
12 [#]	Pin	Φ2.40	Φ2.50	1.2		2.46~3.61	M81969/28-02
	Socket			2.0	14		
				3.0	12		

Contact for X0 series connector is similar to that for X4 series connector. The specific crimping method is similar to that of X4 series connector

X0 Series Shielding

Accessory Description

- In accordance with MIL-DTL-83527B
- EMI shielding
- Environment resistant
- Enterprise standard: Q/21EJ719

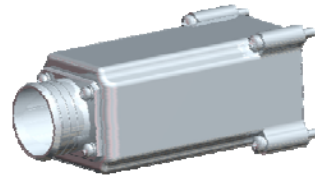

Main technical characteristic

[Mechanical]

- Shock: 11ms half sine wave, acceleration 30g
- Random vibration: 10~2000Hz, power spectral density 0.126g²/Hz, duration: 8h

[Environmental]

- Salt spray: 500h (Cadmium plating) ; 96 h (Nickel plating)
- ▮ Fluid immersion: fuels, coolant, solvent

How to order

Basic series	X0	W	-FJ1A
Plating	W—Cadmium plating F—Nickel plating		
Shell size	FJ1A—shielding accessory for A/C/E cavity FJ2A—shielding accessory for B/D/F cavity FJ3A—shielding accessory for A/C/E cavity FJ4A—shielding accessory for B/D/F cavity		

[Notes]

- The ordering number is relative to the cavity where the accessory is mounted. The adjacent cavities can not be interfered each other

Mounting method for X0F-FJ1A and X0F-FJ2A accessories

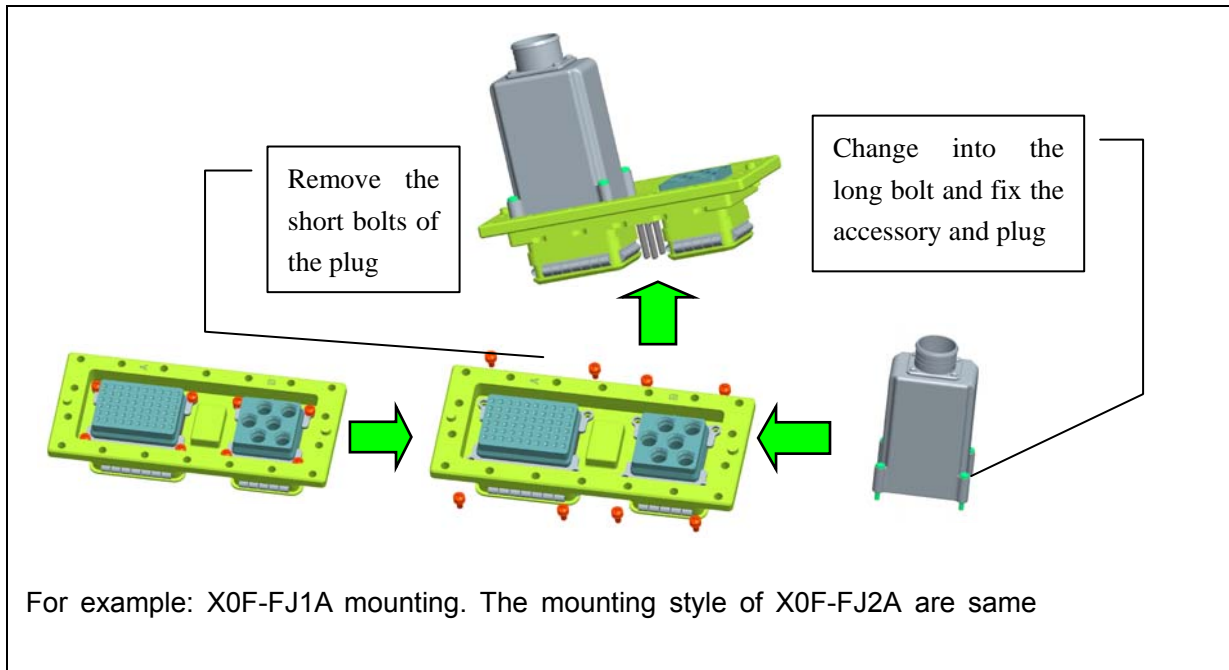

Outline dimensions

X0F-FJ1A basic outline dimension (Unit: mm) (Applicable to A, C and E cavities of X0 series connector)

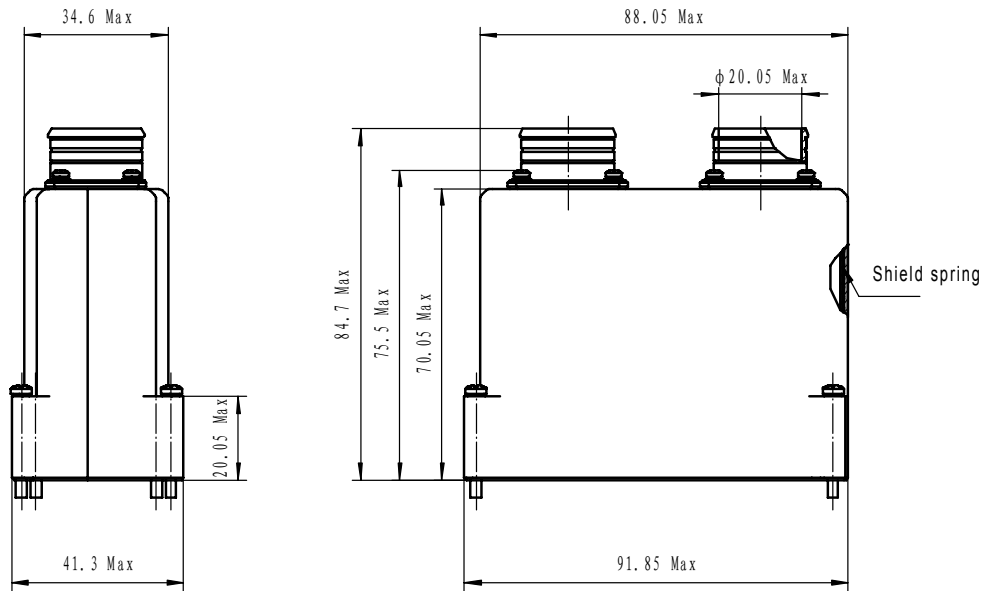

X0F-FJ2A basic outline dimension (Unit: mm) (Applicable to B, D and F cavities of X0 series connector)

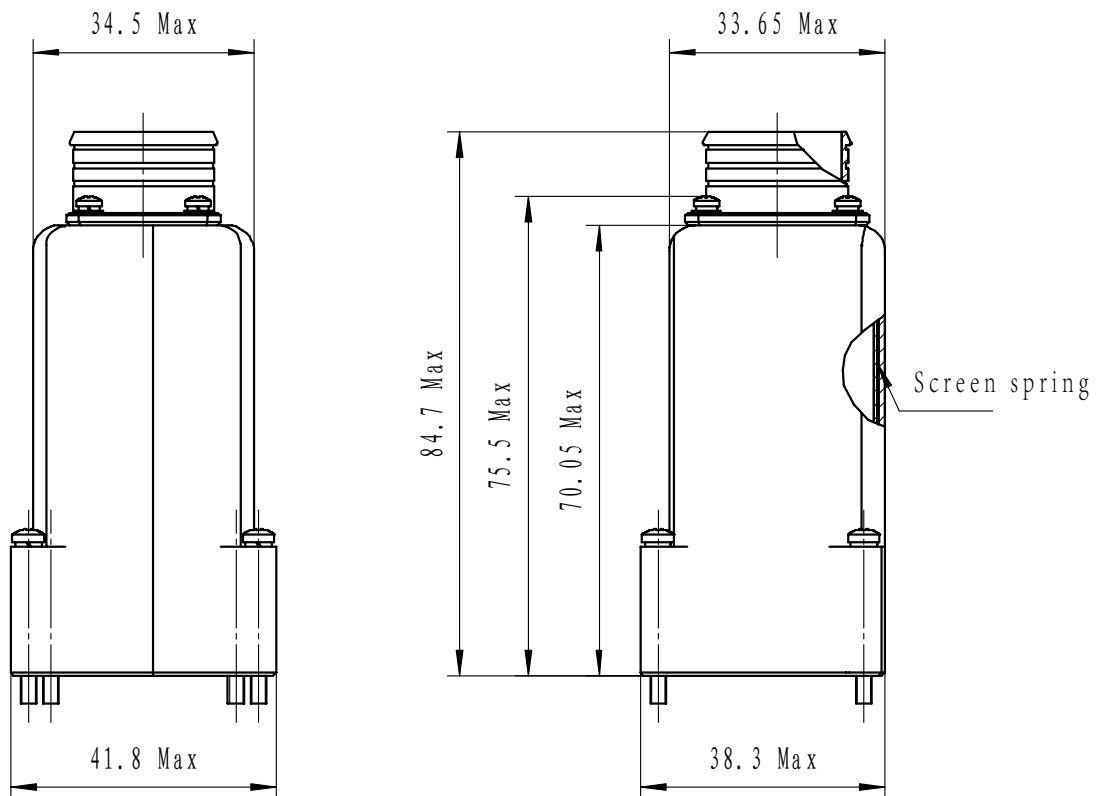



APMA

Mounting method for X0F-FJ3A and X0F-FJ4A accessories

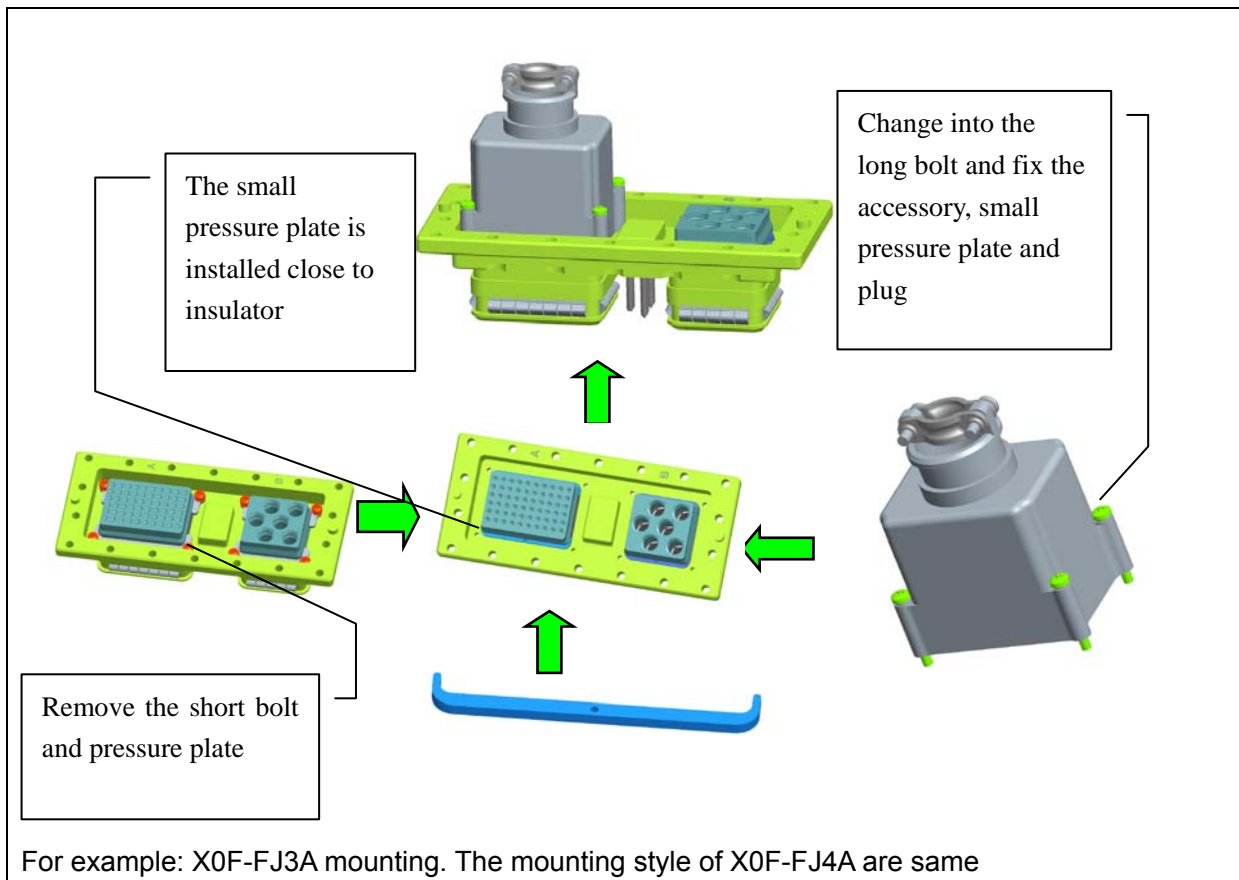

Note: This accessory can clamp and shield the cable and be applicable to the area with higher requirement on shielding. The small pressure plate and the side wall of insulator should be close to ensure the mating and fixation of the shell and plug

Outline dimensions

X0F-FJ3 basic outline dimension (Unit: mm), applicable to A, C and E cavities of X0

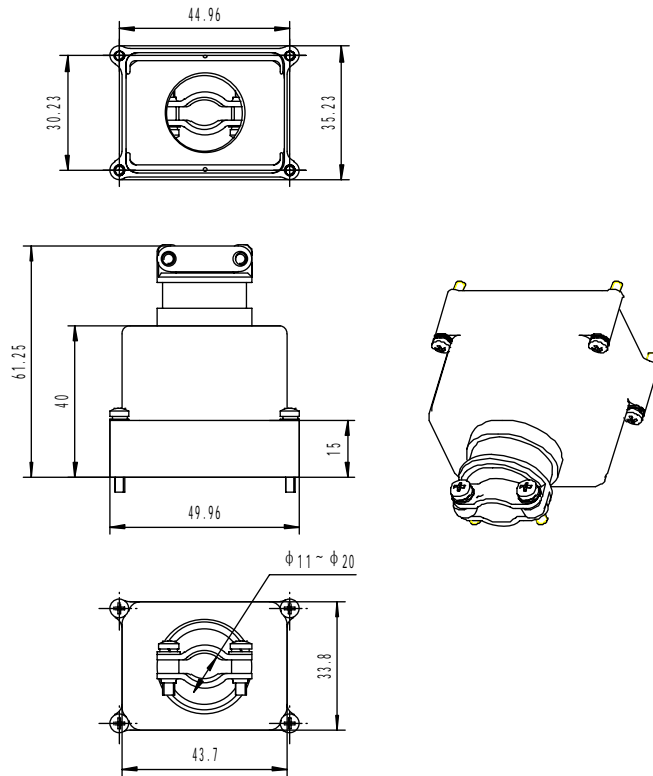

X0F-FJ4A basic outline dimension (Unit: mm), applicable to B, D and F cavities of X0

