

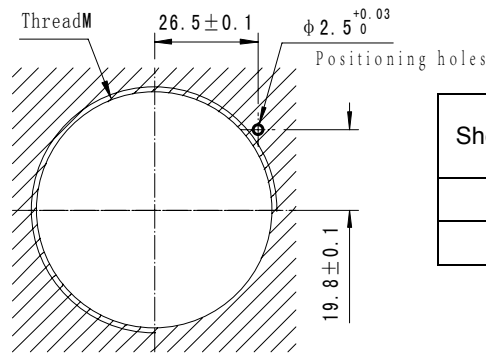



## Recommended panel cutout



Shell size	M	Locating hole
01	58x1.5	yes
02	44x1.5	no

## Contact selection

ZV61 series have 6 kinds of contact sizes. Each contact can be crimped by different wires according to crimp bucket diameter.

See the table below for details:

Number of contacts	Contact size	Applicable pin drawing no.	Applicable socket drawing no.	Applicable national wire standard section (mm <sup>2</sup> )	Applicable American wire (AWG)
37	Φ1.5	21E8.570.2197Au	21E6.571.1689Au	1~1.5	18#~15#
		21E8.570.2198Au	21E6.571.1690Au	0.5~0.75	20#~19#
		21E8.570.2199Au	21E6.571.1691Au	0.14~0.35	26#~22#
14	Φ3	21E8.570.2200Au	21E6.571.1696Au 21E6.571.1698Au(grounding socket)	2.5	13#
		21E8.570.2201Au	21E6.571.1697Au 21E6.571.1699Au(grounding socket)	3~4	12#~11#
7	Φ5	21E8.570.2257Au	21E6.571.1700Au 21E6.571.1702Au(grounding socket)	8.3~10.5	8#~7#
		21E8.570.2258Au	21E6.571.1701Au 21E6.571.1703Au(grounding socket)	4~6	11#~9#
3	Φ6	21E8.570.2259Au	21E6.571.1704Au 21E6.571.1707Au(grounding socket)	2.5~3	13#~12#
		21E8.570.2260Au	21E6.571.1705Au 21E6.571.1708Au(grounding socket)	6~8.3	9#~8#
		21E8.570.2261Au	21E6.571.1706Au 21E6.571.1709Au(grounding socket)	13.3~21.1	6#~4#
1 (01 shell)	Φ11	21E8.570.2262Au	21E6.571.1710Au	16.7	4#
		21E8.570.2263Au	21E6.571.1711Au	67.4	2#
1 (02 shell)	Φ11	21E8.570.1020	21E6.571.1753	—	—

Note:1) When customers select contacts, choose the corresponding contact drawing no in the table above according to their required crimped wire gauge.

2) Contacts for ZV61 series need to be ordered separately;

3) Order one grounding socket for each set of 14, 7 and 3 contacts products

## Crimping tools



Contact size	Crimping tool	Extraction tool
Φ1.5	XCXY	XCQZ-Φ1.5
Φ3	XCXY	XCQZ-Φ3
Φ5	YQK-240(hydraulic pressure tool)	—
Φ6	YQK-240(hydraulic pressure tool)	—
Φ11	YQK-240(hydraulic pressure tool)	—

\* Use method for hydraulic pressure tool will be supported by our special technicians.